

COLOR INDEX table with columns for PLOT BOUNDARY, ABUTTING ROAD, PROPOSED WORK, EXISTING, and EXISTING (To be demolished).

AREA STATEMENT (BBMP) table with columns for PROJECT DETAIL, AREA DETAILS, COVERAGE CHECK, and FAR CHECK.

Approval Condition: This Plan Sanction is issued subject to the following conditions: 1. The sanction is accorded for: a) Consisting of Block - A (A) Wing - A-1 (A) Consisting of BASEMENT, GF-ZULF...

31. Sufficient two wheeler parking shall be provided as per requirement. 32. Traffic Management Plan shall be obtained from Traffic Management Consultant for all high rise structures...

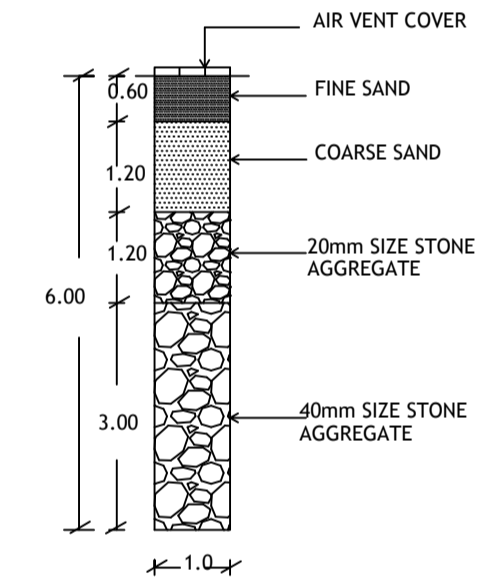

C/S OF RWH PIT

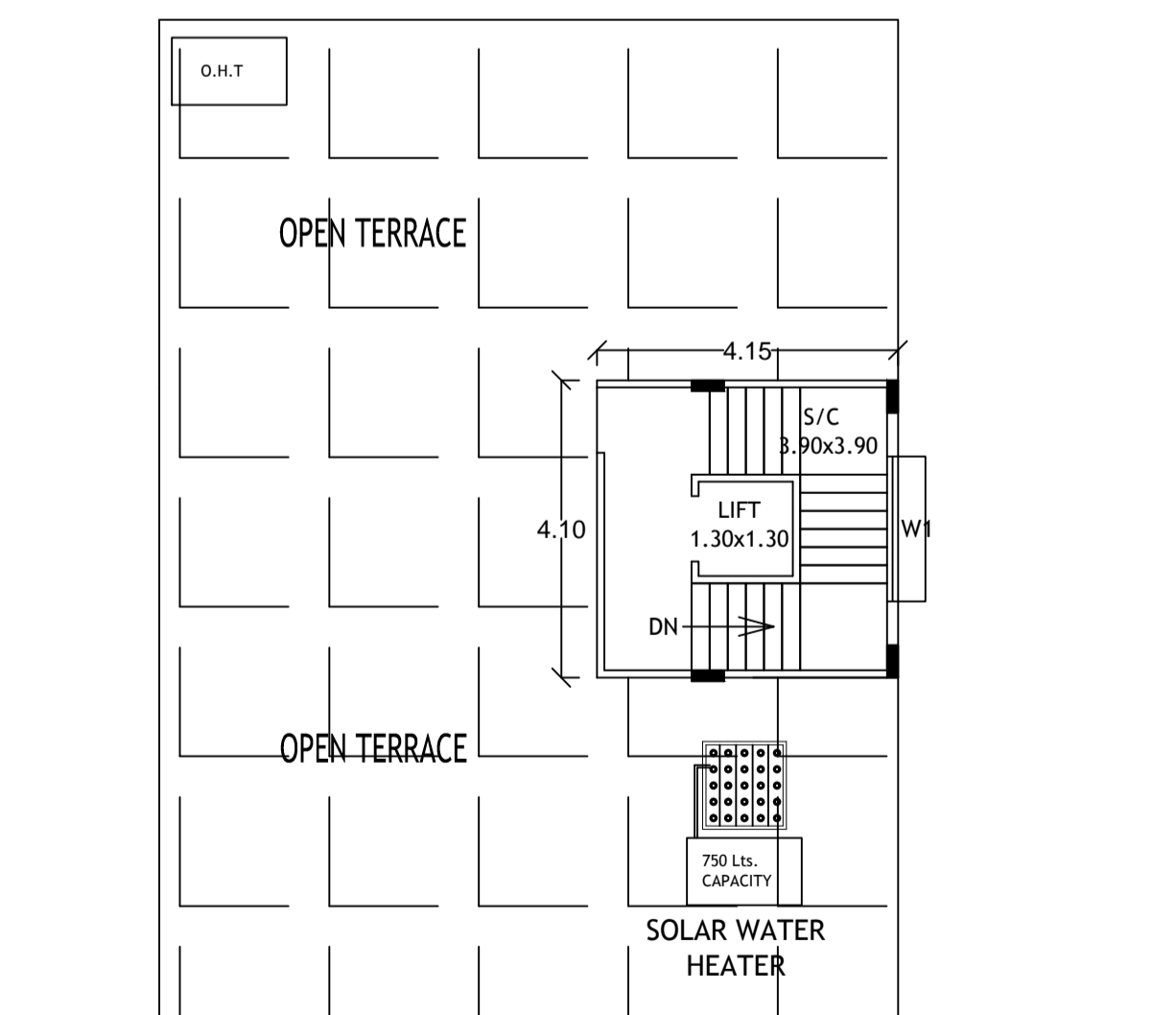
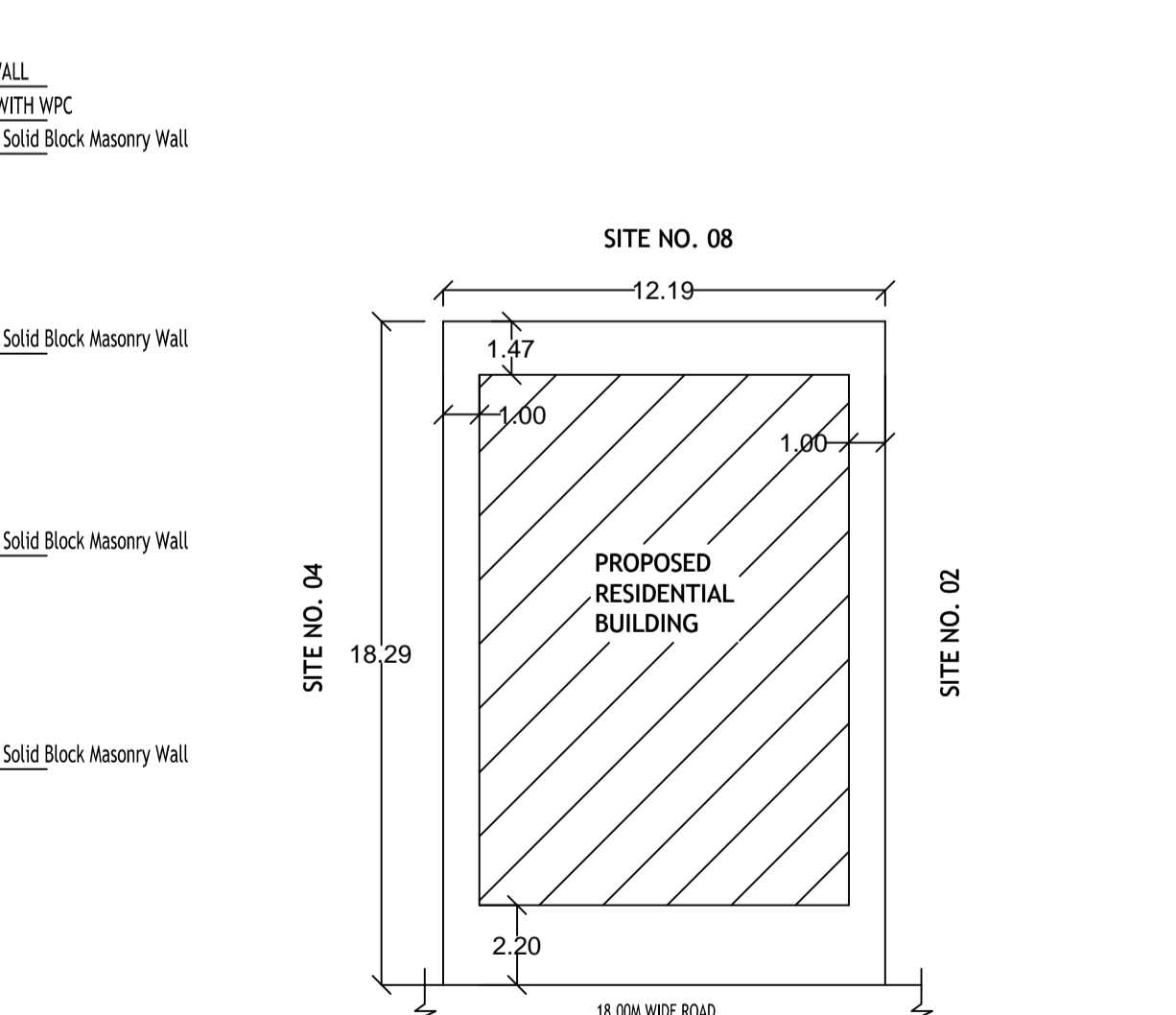
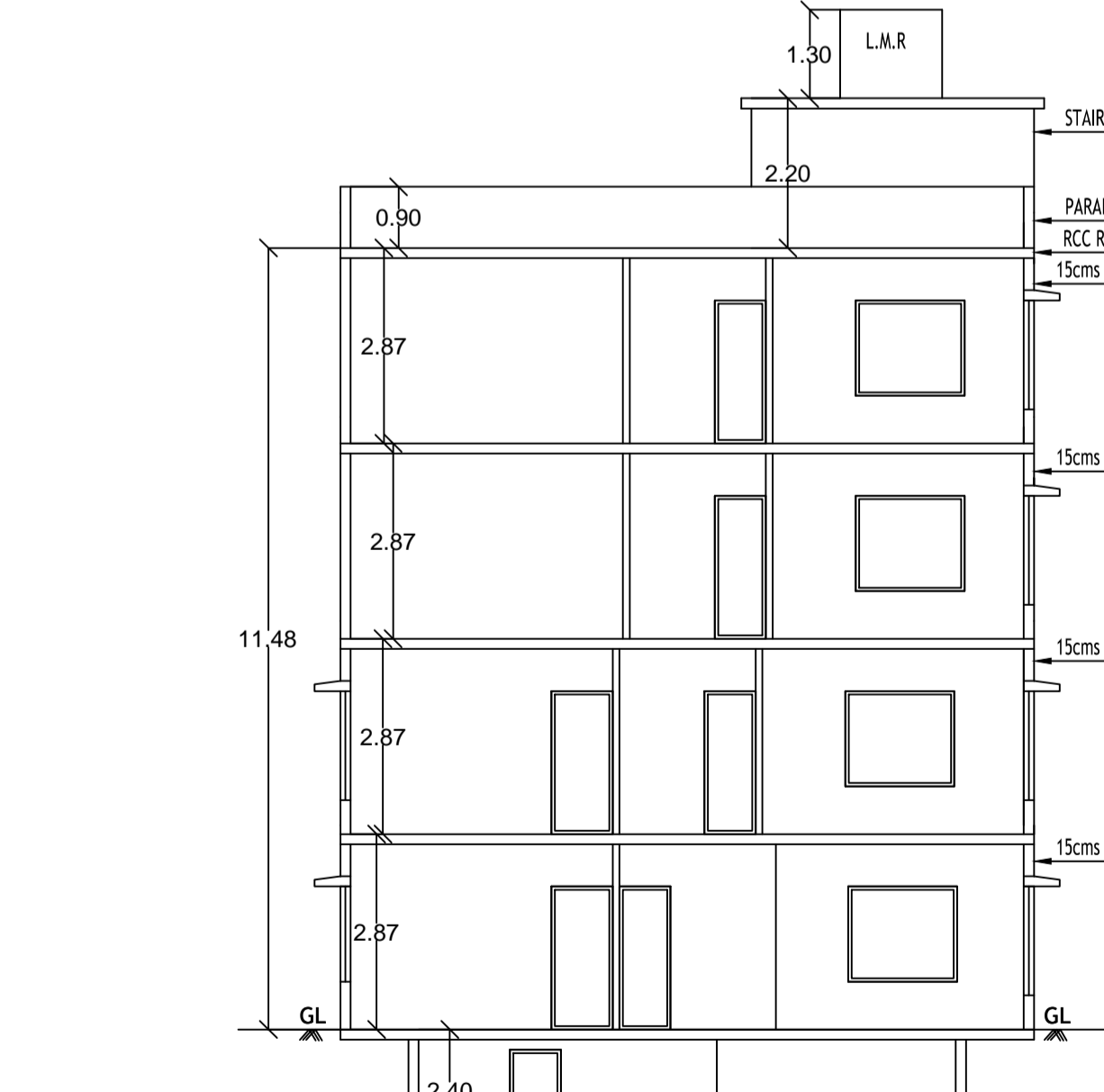

FAR & Tenement Details table with columns for Block Name, Gross Built Up Area, Deductions, Proposed FAR Area, Total FAR Area, and Tenement (No.).

Parking Check (Table 7b) table with columns for Reqd. and Achieved for Car, Total Car, TwoWheeler, and Other Parking.

Block USE/SUBUSE Details table with columns for Block Name, Block Sub/Use, Block Structure, and Block Land Use Category.

Required Parking (Table 7a) table with columns for Block Name, Type, Sub/Use, Area, Units, and Car Reqd.

Block A (A) table with columns for Floor Name, Gross Built Up Area, Deductions, Total Built Up Area, Deductions (Area in Sq.mt), Proposed FAR Area, Total FAR Area, and Tenement (No.).

Approval Date: SCHEDULE OF JOINEERY table with columns for BLOCK NAME, NAME, LENGTH, HEIGHT, and NOS.

SCHEDULE OF JOINEERY table with columns for BLOCK NAME, NAME, LENGTH, HEIGHT, and NOS.

UnitBUA Table for Block A (A) table with columns for FLOOR, Name, UnitBUA Type, UnitBUA Area, Carpet Area, No. of Rooms, and No. of Tenement.

OWNER / GPA HOLDER'S SIGNATURE: VINAY C. MUSALE & M.S. SHUBHA #NO. 114, 4TH CROSS, 1ST PHASE, 2ND STAGE, CHANDRA MOHAN NEAR POLICE STATION, VIJAYANAGAR, BANGALORE.

ARCHITECT/ENGINEER /SUPERVISOR'S SIGNATURE: vinod P

PROJECT TITLE: PROPOSED RESIDENTIAL BUILDING AT SITE NO. 22, 60 FEET ROAD, KANAKA NAGAR, BANGALORE, WARD NO. 103, PID NO. 37-130-22

DRAWING TITLE: 1548390238-20-07-2021-03-01-245\_ \$40X60 VINAY C MUSALE REV 1

SHEET NO: 1

SANCTIONING AUTHORITY table with columns for Block Name, Block Sub/Use, Block Structure, and Block Land Use Category.

WEST